

# LUCAS

"CYCLEALITIES" AND  
"MOTOR-CYCLEALITIES"



## 1930

EXPORT

*Long after Price is forgotten.*



Front Fork Brackets No. 39 are designed to enable the Projector to be conveniently fitted to the front forks—a very popular fitting. These brackets are supplied to suit either  $\frac{3}{4}$  in. or  $\frac{1}{2}$  in. forks.

The Girder Sports Brackets No. 48, fitted on the No. 462S Sports Set, enable the Projector to be set well ahead of the handle-bars, to complete the general outline of a Sports Machine. They are strong and rigid and designed to withstand vibration.

A Double Bracket, carrying Projector and Generator on the handle-bar, is included in the No. 462 Set. It can be fixed to most standard machines, is adjustable for level, and will fit  $\frac{3}{4}$  in. or 1 in. bars.

All brackets are fitted with the new Lucas ball socket mounting which enables the Projectors to be set correctly without strain either to the lamps or brackets.

Front,  $6\frac{1}{2}$  in. Glass, 5 in. Burner No. 52

**COMPLETE SET No. 462S comprises:—**

- Projector No. 462.
- Generator No. 62.
- Generator Bracket No. 37.
- Girder Brackets No. 48 for handle-bar and Tubing.

Code Word  
LACRO In Ebony Black finish .. .. .

**COMPLETE SET No. 462 comprises:—**

As above, but without Generator Bracket No. 37, and with Double Brackets No. 61B for handle-bar instead of Girder Brackets No. 48.

Code Word  
LAADA In Ebony Black finish .. .. .

**Ebony Black** is the standard finish, but Nickel Plated can be supplied if ordered.

# LUCAS

“KING OF THE ROAD”  
MOTOR-CYCLE  
PROJECTOR  
SET N° 462S

(ACETYLENE)

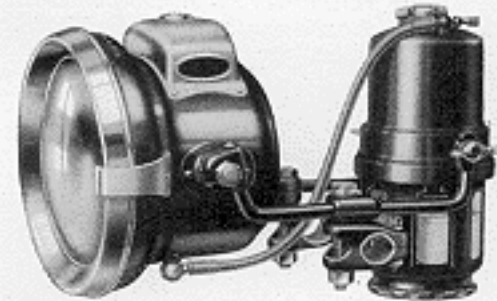

NO. 462 SET  
WITH DOUBLE BRACKET

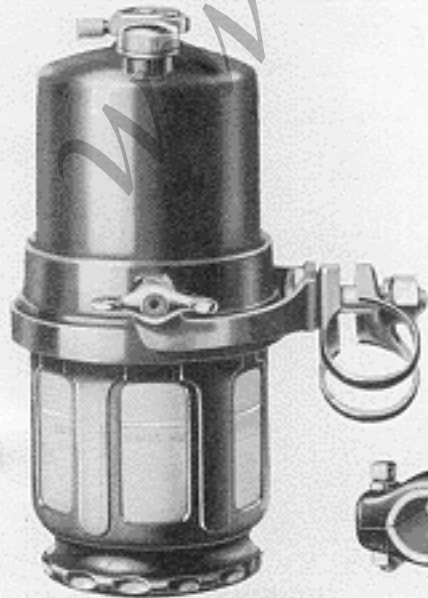

“KING OF THE ROAD”  
NO. 462S SET  
(SPORTS MODEL)

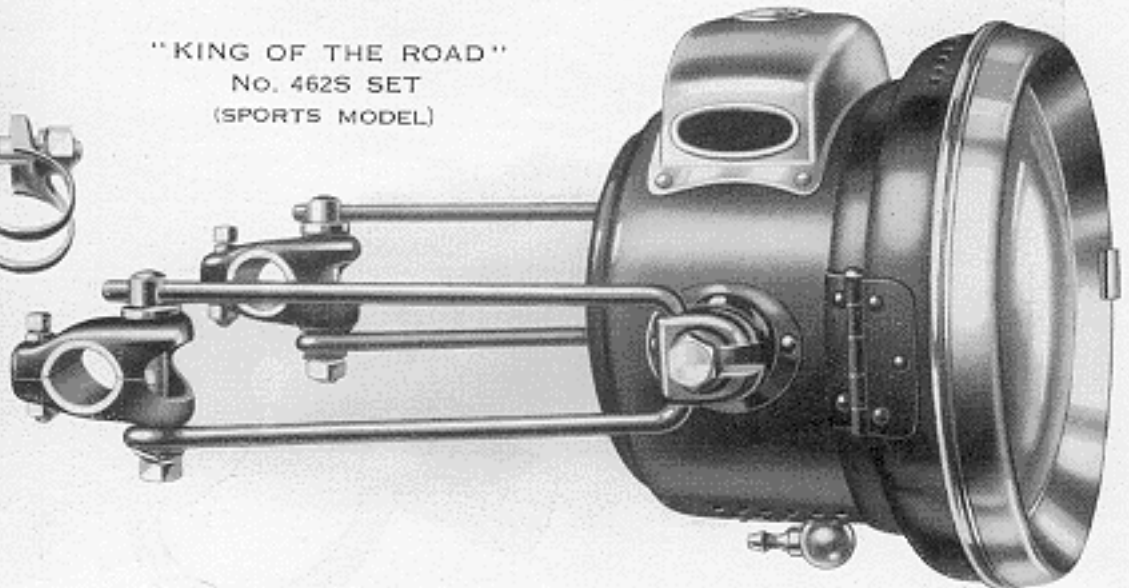

# King of the Road



## LUCAS

### COMPLETE SEMI-SPORTS EQUIPMENT FOR MOTOR-CYCLES

The Complete Equipment Set "D," illustrated below, is listed as standard by many Motor-Cycle Manufacturers.

The Complete Set comprises Projector with Brackets, Generator with Bracket, Tail Lamp and Bulb Horn, and is listed at an inclusive price.

The Projector is fitted with a Reflector Extension and a Silvered Mirror Reflector optically designed to project a powerful penetrative light a considerable distance and to give the necessary width of beam near the rider. The Brackets are designed to fit into the lugs on the front forks, making a neat method of fixing the lamp.

The two-way feed on the Generator enables the tail lamp to be supplied with gas, as well as the head lamp. The Generator is of the drip-feed type, has our quick-action carbide container attachment, and its bracket makes it adaptable for fitting in the most convenient position.

The Tail Lamp and Bulb Horn are our standard models, and are listed in detail on pages 41 and 43 respectively.

The COMPLETE SET comprises:—

Projector (with Brackets)	..	No. 420.
Generator	..	No. 42.
Generator Bracket	..	No. 37.
Tail Lamp	..	No. 344.
Bulb Horn	..	No. 63.
Complete with necessary tubing, etc.		

Code Word

LECOF Price of Set "D" as above, Ebony Black finish

If a Side-Car Lamp is required to be used in conjunction with above equipment, No. 350 Set, described and illustrated on page 40, is recommended.

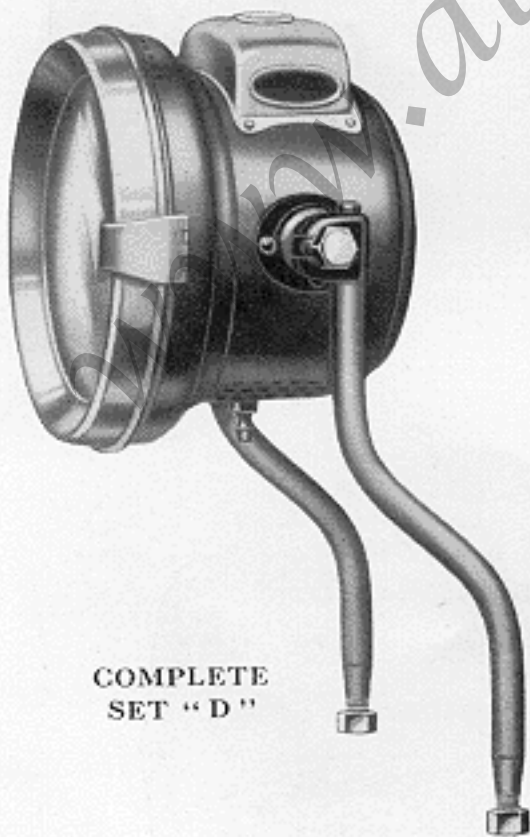

COMPLETE  
SET "D"



GENERATOR  
NO. 42 WITH  
BRACKET  
NO. 37



TAIL LAMP  
NO. 344



"KING OF THE ROAD" HORN No. 63

# King of the Road



# LUCAS

**"KING OF THE ROAD"**  
**MOTOR-CYCLE**  
**PROJECTOR**  
**Nº H52 . . . .**

NEW MODEL  
 WITH DIPPING BEAM  
 DEVICE

No. H52 Motor-Cycle Projector is a new large model which incorporates many novel and exclusive features, and is used in our "Magdno" and Dynamo Sets.

It is a robust pattern with a 7 1/4 in. front which is pleasing and smooth in outline. It has a 6 in. diameter parabolic silvered reflector of correct optical design, and its highly finished surface has a transparent protective coating which is untarnishable. The lamp is fitted with a Lucas Blue \* Star double-filament 24-watt gas-filled bulb which gives a brilliant high-power driving light. One filament is arranged to be practically at the focus of the reflector, and gives a normal driving light, while the second filament (also 24-watt) is mounted slightly above the other. This gives a dipped non-dazzling beam for use when meeting traffic or driving in fog or mist. This anti-dazzle device is controlled by a neat switch conveniently mounted on the handle-bar.

A small 3-watt pilot bulb is also provided for use when the machine is stationary or for town driving.

Other special features are as follows:—

A new moulded switch, controlling the lamp and the charging of the battery, is fitted to the back of the lamp. The switch handle is particularly large so that it can be easily operated even when wearing thick gloves.

The four positions are:—

- "OFF." Lamps off, and dynamo not charging.
- "C." Lamps off and dynamo giving half its normal output.
- "H." Headlamp (driving light), tail lamp, and side car lamp (when fitted) on. Dynamo giving maximum output.
- "L." The conditions are exactly the same as in position "H," with the exception that the pilot bulb functions instead of the driving light.

A centre zero ammeter, readily visible to the rider, is mounted on the top of the lamp, and is illuminated by indirect lighting which has no distracting glare.

All cables are taken directly to the switch at the back of the lamp. The switch is secured by two screws and can be readily withdrawn from the lamp complete with cables.

There are no wires inside the lamp, connections being made by spring blades.

To move the bulb inwards, it is only necessary to turn in a clockwise direction, and vice versa.

The girder brackets are strong and rigid, and the ball socket mounting allows the lamps and brackets to be correctly set without strain to either.

Front, 7 1/4 in. Aperture, 6 1/4 in. Weight, 2 1/2 lb.

Code Word	No.	Finish
EDMAX	H52	Ebony Black, with Switch, Illuminated Ammeter, Dip-beam Control Switch for handle-bar, Cable Harness and Girder Brackets . . . . .
EDLYC	H52	As above, but without Cable Harness and Handle-bar Switch . . . . .

For particulars of Spare Bulbs see page 59.

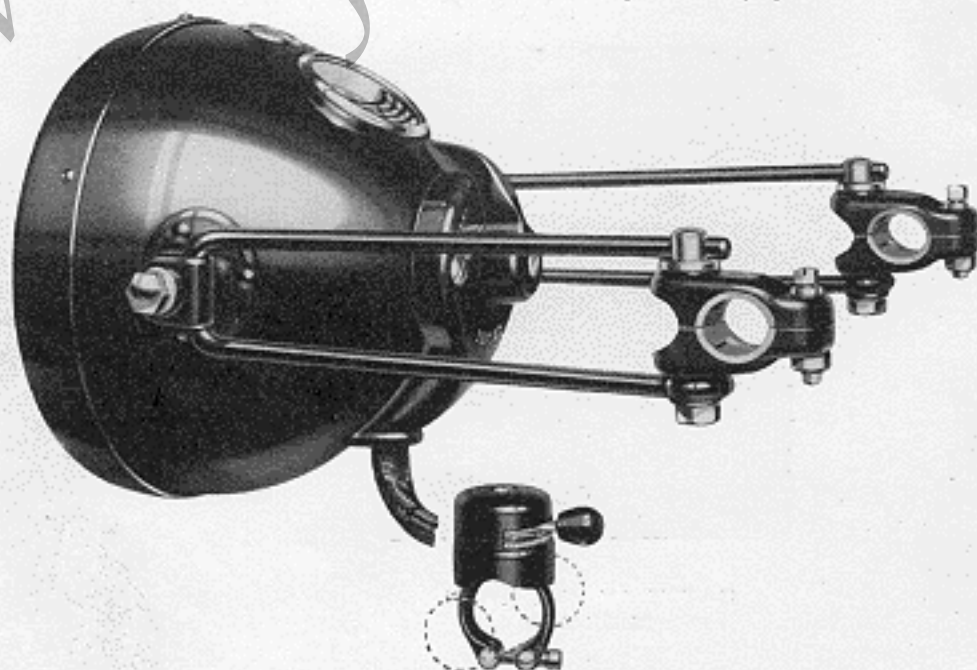

LUCAS No. H52 PROJECTOR  
 WITH SWITCH, ILLUMINATED AMMETER,  
 DIP-BEAM CONTROL SWITCH, AND  
 GIRDER BRACKETS

# The Best of Everything



KING OF THE ROAD

## LUCAS MOTOR - CYCLE BATTERIES

Lucas Batteries, in common with all other electrical products of the Company, have long held a leading place in the branch of electrical engineering connected with the motor-cycle industry, and have proved their worth by giving reliable and steady service under everyday running conditions.

They are the outcome of many years of continuous research at our own Works, and are manufactured under the best conditions and with the latest and most improved plant.

Our experience as large manufacturers of Batteries and Lighting Sets is embodied in the changes which have been made from time to time in the various models, and we are confident that our product more than ever meets the needs of the motor-cycling public.

A notable advance was made when we introduced our new moulding material, known as "Milam" (Moulded In Lucas Acid-proof Material). The use of this material for cell construction has eliminated the troubles which are experienced with leaking Batteries, and not only has it added to the mechanical strength of the Battery, but the elaborate moulding processes following the use of this new material have enabled us to effect great improvements in the design, and to make the appearance of the Battery very attractive.

Our Separators give the necessary rigidity to the Section and ensure free diffusion of the electrolyte and low internal resistance.

A special characteristic of all Lucas Plates is their low voltage drop on discharge.

### 4-VOLT BATTERY ("Milam").

Code Word	Type	Volt.	Amp. hours	Over-all Dimensions	
ACLOP	LOW5G	4	9	5 1/2 x 2 1/2 x 7 1/2 in.	Battery only .. ..
ACLUK	LOW5G	4	9		With Solo Fittings .. ..

### 6-VOLT BATTERIES ("Milam").

ACRLA	LH5E	6	12	5 1/2 x 5 1/2 x 5 1/2 in.	Battery only .. ..
ACRKY	LH5E	6	12		With Solo Fittings .. ..
ACRKY	LH5E	6	12		With Side-Car Fittings .. ..
ACLH	LW7E	6	12	4 1/2 x 3 1/2 x 6 1/2 in.	Battery only .. ..
ACLID	LW7E	6	12		With Solo or Side-Car Fittings .. ..

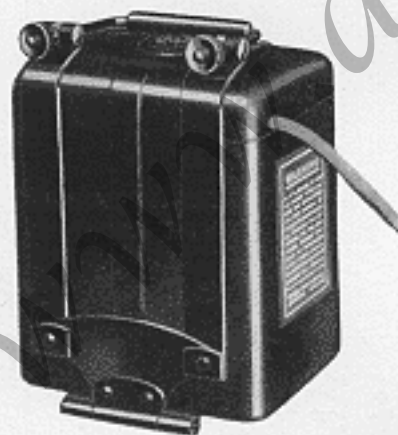

LUCAS LOW5G & LW7E  
TYPE OF BATTERY FOR  
MOTOR-CYCLES



LUCAS  
BATTERY No. LH5E  
WITH SOLO FITTINGS

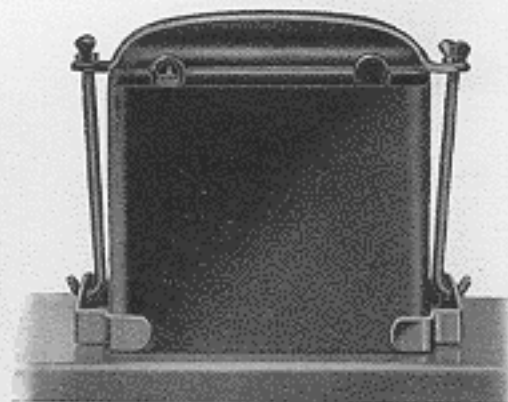

LUCAS  
BATTERY No. LH5E  
WITH SIDE-CAR FITTINGS

**Packing and Delivery.** Goods are suitably packed in strong iron-hooped cases with waterproof paper lining, which are charged for at cost. Every care is exercised to ensure adequate protection, and the Company cannot entertain claims for any damage that may be sustained in transit. Our responsibility as to safe delivery ceases upon receipt by Transportation Company of material noted on Bill of Lading in good order.



*The Memory of Quality remains*

# LUCAS

## "MAGDYNO"

(REG.)

(LIGHTING AND IGNITION), FOR

SOLO

MOTOR-CYCLES

The Lucas "Magdyno" (Combined Lighting and Ignition) Set enables the Motor-Cyclist to have the advantages of car lighting. With the "Magdyno," only a turn of the switch is necessary to give a brilliant and even flood of light over the whole width of the road for a tremendous distance ahead, besides providing a healthy spark for ignition at all speeds. Most well-known makers now catalog their machines with Lucas Electrical Equipment as standard at an inclusive price, or as an alternative.

Lucas Equipment is subjected to constant testing and research, and its continued and progressive advance in detail of design is proved by its popularity and the fact that it is fitted to-day by the thousand as standard, or when specified. The cover is of improved shape and can be removed without disconnecting the cables. The magneto section carries the Lucas Magneto guarantee, and has special features developed by racing performance. The "Magdyno" is a full-size machine (30 watts, i.e., output of 3 amps. at 6 volts) and, as the name suggests, consists of two units: a magneto for ignition, and a dynamo for charging the battery, both units being neatly housed within an aluminium body. Power is transmitted to the dynamo (the upper unit) by gears driven from the magneto spindle. The machine is thus equivalent to a somewhat taller magneto, the size as regards bolt hole centres and height of spindle remaining the same as the ordinary standard magneto, the same chain and gear drive for the latter sufficing for the "Magdyno."

Length,  $7\frac{3}{8}$  in.      Width,  $4\frac{1}{4}$  in.      Height,  $6\frac{3}{8}$  in.      Weight, 13 lb.

"MAGDYNO" SOLO SET comprises:—

"Magdyno" (for Single-Cylinder Engines).

Projector No. H52 (with Switch, Illuminated Ammeter and Dip-beam Control Switch for handle-bar) described on page 50

Tail Lamp No. MT110 described and illustrated on page 51

Battery No. LUW7E (Lucas "Milam") .. .. . 52

Set of Cables, etc., etc.

Price of Set complete, in Ebony Black finish .. .. .

Extra for Two-Cylinder "Magdyno" .. .. .

Extra for "Lucas-Nife" Steel-Plate Battery .. .. .

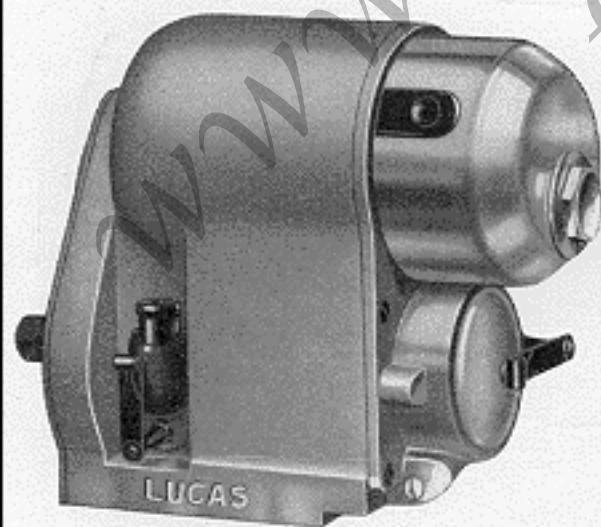

LUCAS "MAGDYNO"

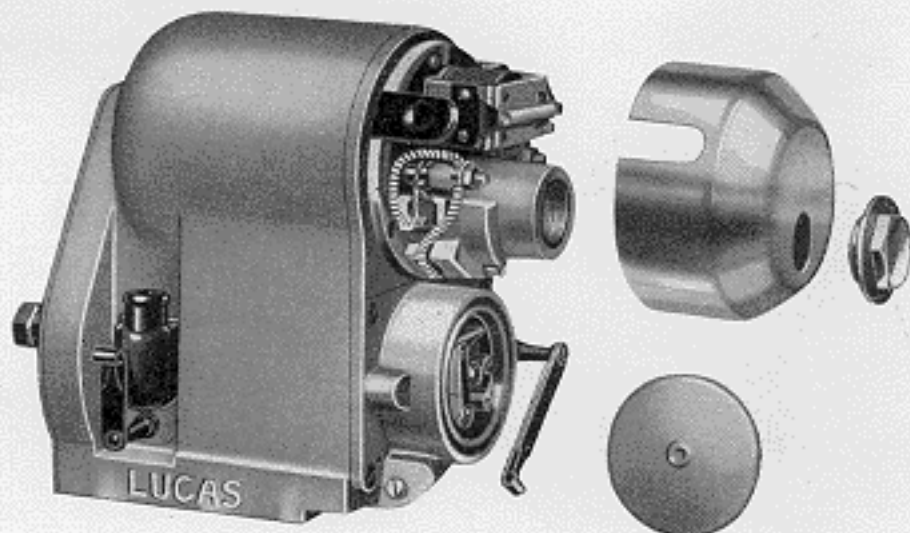

"MAGDYNO" (COMMUTATOR AND CONTACT BREAKER COVERS REMOVED)

*Long after Price is forgotten.*



*Continued.*

enabling it to be fitted without the provision of an extra drive. The weight of the machine is 13 lb. only, and therefore is very little heavier than the standard magneto. The cut-out is of robust design, the gear drive is 45% stronger than in earlier models, there are no intermediate gears, and the moulded terminals are waterproof.

A special feature of Lucas "Magdynos" is the method of output control. During daytime running the dynamo is arranged to give an ample output which ensures that the battery is charged at a suitable rate without liability to excessive overcharging, and is thus kept in good condition.

At night when the lamps are switched on the "Magdynamo" automatically gives an increased output which compensates for the lamp load and prevents the battery from being unduly run down.

This method of control is obtained by inserting a resistance in the dynamo field circuit which is automatically cut out whenever the lamps are switched on. The arrangement has the merit of simplicity and entire absence of vibrating parts.

To owners of motor-cycles already in use we are willing to make the best possible allowance for the old magneto, according to its age. Full particulars are given on application.

Specifications of the complete "Magdynamo" Sets, for Solo or Combination Machines, are given below, and the various component parts are illustrated and described on the pages of this Catalog detailed below.

Base Plate and Centres are of accepted standard size.

**"MAGDYNO" COMBINATION SET comprises:**

"Magdynamo" (for Single-Cylinder Engines).

<b>Projector</b>	No. H52 (with Switch, Illuminated Ammeter and Dip-beam Control Switch), described on page 50	
<b>Tail Lamp</b>	No. MT110 described and illustrated on page 51	
<b>Side-Car Lamp</b>	No. R370	" " 51
<b>Battery</b>	No. LUW7E (Lucas "Milan")	" " 52
<b>Set of Cables, etc., etc.</b>		

**Price of Set complete, in Ebony Black finish .. .. .**

*Extra for Two-Cylinder "Magdynamo" .. .. .*

*Extra for "Lucas-Nife" Steel-Plate Battery .. .. .*

**LUCAS**  
**"MAGDYNO"**  
 (REG.)  
**(LIGHTING AND**  
**IGNITION), FOR**  
**COMBINATION**  
**MOTOR-CYCLES**

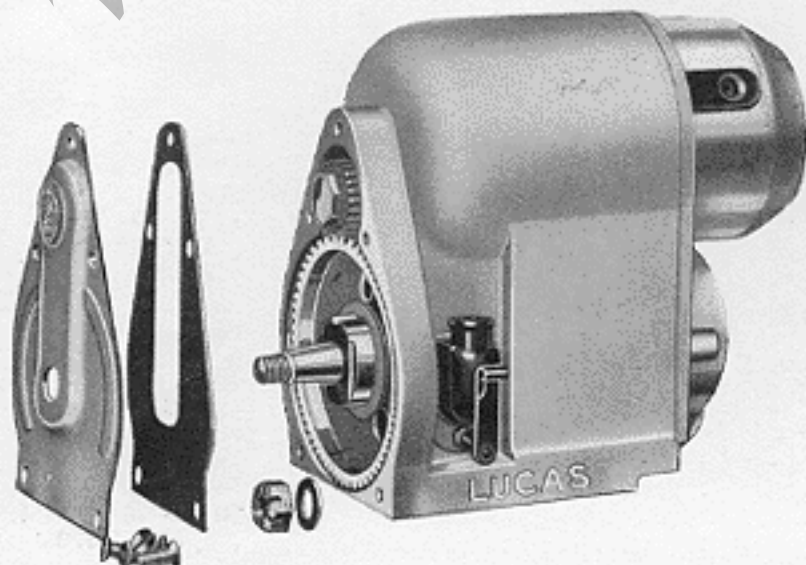

"MAGDYNO" (WITH GEAR COVER REMOVED)

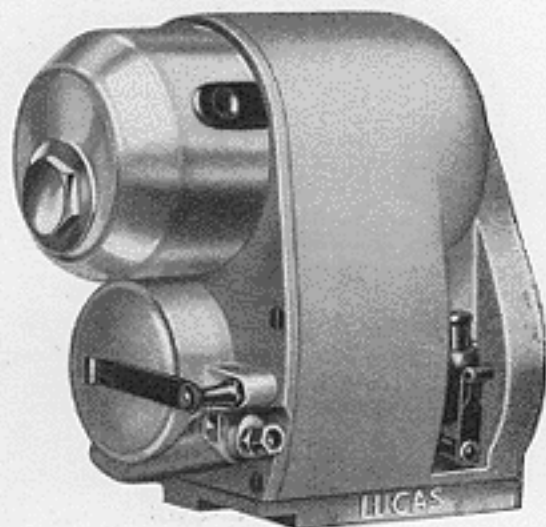

LUCAS "MAGDYNO"

The Best of



Everything

KING OF THE ROAD

# LUCAS DYNAMO LIGHTING SETS . . .

6 VOLT

Lucas Dynamo Lighting Sets are available for motor cycles where it is found inconvenient to fit the "Magdyno" Set.

Two sizes of dynamos are manufactured, E3 for a 6-volt set, and a smaller one, E25, for a 4-volt set, which is particularly suitable for light-weight models.

Both these dynamos begin to charge at low road speed, rapidly increasing to their maximum output.

The regulation of the dynamo is effected by means of the well-known third brush method. The dynamos are constructed with the cut-out mounted on the end bracket, as this makes the system compact and simplifies the external wiring of the set.

The moulded terminals are designed so that when the dynamo is wired up with 5 mm. cable the connections are quite watertight.

The cover protecting the cut-out and brush gear can be removed without disconnecting the cables.

A special feature of Lucas Dynamos is the method of output control. During daytime running the dynamo is arranged to give an ample output which ensures that the battery is charged at a suitable rate without liability to excessive overcharging, and is thus kept in good condition.

At night, when the lamps are switched on the Dynamo automatically gives an increased output which compensates for the lamp load and prevents the battery from being unduly run down.

Overall Length, 6 1/4 in. Diameter, 3 in. Weight, 5 lb. 1 oz.

**E3 6-VOLT DYNAMO SOLO SET comprises:—**

- E3 Dynamo 6-Volt. Maximum output, 4 to 5 amps. at 4,000 r.p.m.
- Projector No. H52 (with Switch and Illuminated Ammeter, etc.), described on page 50.
- Tail Lamp No. MT110, described and illustrated on page 51.
- Battery No. LUW7E (Lucas "Milam"), described and illustrated on page 52.
- Set of Cables, etc.

Price of Set complete, in Ebony Black finish . . . . .

**E3 DYNAMO COMBINATION SET** comprises as above, but with Side-Car Lamp R370 (see page 51).

Price of Set complete, in Ebony Black finish . . . . .  
Extra for "Lucas-Nife" Steel-Plate Battery . . . . .

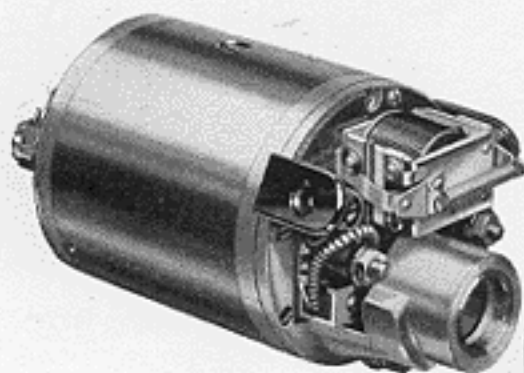

LUCAS  
DYNAMO No. E3  
WITH END COVER REMOVED  
SHOWING CUT-OUT



TAIL LAMP NO. MT110

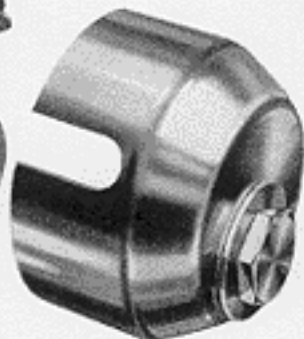

SIDE-CAR LAMP  
No. R370